

NAVII®



INTRODUCTION

Navii is a durable, waterproof microprocessor knee (MPK) with unparalleled freedom of movement. Navii ensures confidence in every step, no matter the terrain. Available in five nature-inspired colors, Navii's protective covers can be effortlessly switched with a magnetic snap-on to suit any occasion.

KEY FEATURES

- Strong actuator with innovative control technology and smooth swing dynamics.
- Waterproof Design (IP68, Pool, Ocean, Beach and Sand)
- Patient removable protective covers available in 3 different sizes. Medium and Long sizes easily customizable to various lengths. Standard size available in 5 different colors.
- Variable position mechanical lock which can be locked at 0°, 10° and 20°
- Accompanying Össur Logic app control center for all Össur bionic devices.
- Easy setup and fitting through the set-up wizard and powerful auto-adjustment
- Step-by-step functional training exercises for both in-clinic and at-home training through Össur Logic app.
- Progress tracking through printable activity reports.
- High Activity Features (step-over-step ascent, automatic cycling recognition, seamless transition into running)



RECOMMENDED WITH



Seal-In® X TF liner



Pro-Flex® Terra



Proprio Foot®



Pro-Flex® LP



Pro-Flex® XC

NAVII®



User Information		
Amputation Level:	Transfemoral, Knee disarticulation, Hip disarticulation	
Osseointegration:	Yes	
Bilateral:	Yes	
Impact Level:	Low to moderate	High
Maximum Patient Weight:	136 kg (300 lbs)	110 kg (243 lbs)

Knee Information	
Net weight:	1.8 kg (4.0 lbs) without protective cover 2.0 kg (4.4 lbs) with protective cover
Build Height:	236 mm (9 ¼")
Knee Flexion:	-2 to 120°
Waterproof:	IP68, Salt, Chlorine, Sand, Soap, Bodily Fluids

CLEARANCE

DIMENSIONS WITHOUT PROTECTIVE COVER

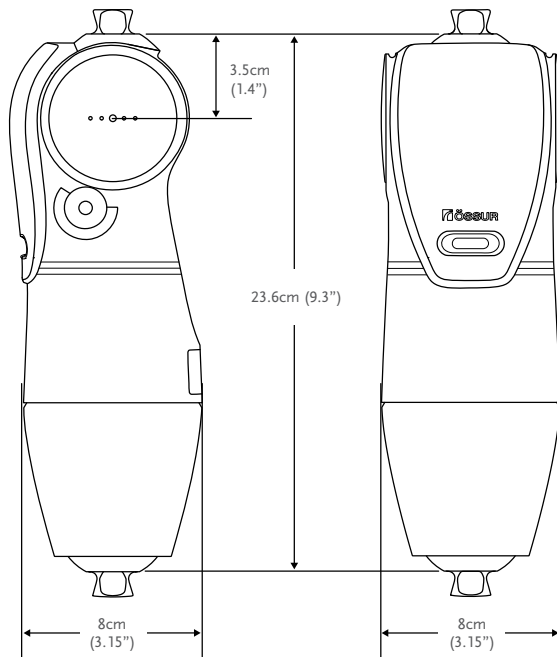

DIMENSIONS WITH PROTECTIVE COVER

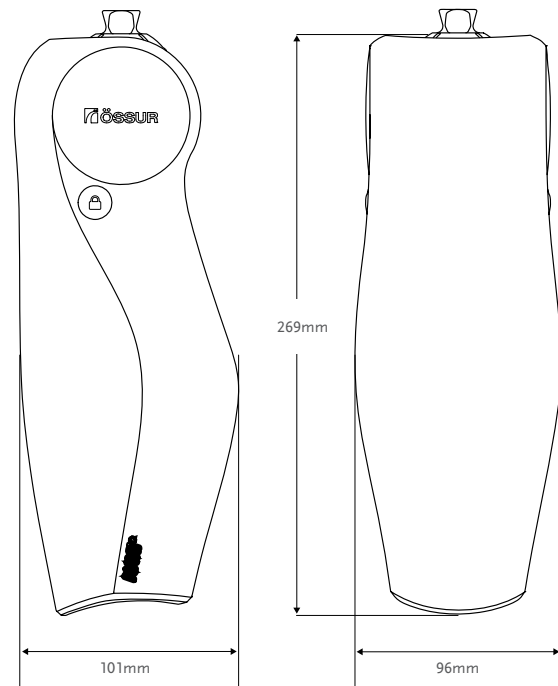

NAVII®

KITS

NAVII KITS

Part#	Description
NAV01002	Navii incl 2Yr Warranty
NAV01003	Navii incl 3Yr Warranty
NAV01005	Navii incl 5Yr Warranty
NAV01006	Navii incl 6Yr Warranty
NAV01FR6	Navii France incl 6Yr Warranty, w/o Service Check



Includes:

- Navii (including standard black protective cover)
- Navii power supply w/plug
- Instructions for Use
- NAV01005 & NAV01006 include scheduled service check at 40 months

NAVII KIT WITH THREADED TOP ADAPTER:

Navii with threaded top adapter is the solution for knee disarticulation amputees and those with long residual limbs.

To order Navii with threaded top adapter, order the Navii Kit and add Össur 's Female Pyramid Insert to the order.

Part#	Description	Height	Weight
A-145310	Female Pyramid Insert / Threaded Top Adapter	9mm 3/8"	33g 1.16oz



NAVII KIT WITH FLEXION TRANSLATION ADAPTER:

Navii with flexion translation adapter is the solution for socket flexion adjustments greater than what is allowable with the set screws.

To order Navii with flexion translation adapter, order the Navii Kit and add Össur 's male/female double adapter with 8mm offset and 10° angle to the order.

Part#	Description	Material	Height	Build Height	Weight
A-554700	Male-Female double adapter	Stainless steel	40mm 1 37/64"	24mm 15/16"	153g 5.8oz



NAVII®

EXTENDED WARRANTY

Part#	Description
NAV01GE3Y	Navii Warranty Extension, 3Yr

Warranty extension includes scheduled service check at 40 months. Warranty extension can be added to Navii Kits NAV01002 & NAV01003 and can be purchased anytime while the product is still under warranty. Maximum total warranty period is 6 years.

SERVICE CHECKS

Part#	Description
NAV01SC40	Navii Service Check, Mandatory 40 Months
NAV01SC20	Navii Service Check, Voluntary 20 Months

Service options can be purchased separately.

REPLACEMENT PARTS

NAVII PROTECTIVE COVER

Part#	Description
NAV01PC01S-BLK	Navii Protective Cover, Standard, Black
NAV01PC01S-GRY	Navii Protective Cover, Standard, Grey
NAV01PC01S-BLU	Navii Protective Cover, Standard, Blue
NAV01PC01S-GRN	Navii Protective Cover, Standard, Green
NAV01PC01S-RED	Navii Protective Cover, Standard, Red

Protective Covers include warranty of 6 months.



UNITY

UNITY KITS

Part#	Description	Applicable Foot Kits
UTF0001	Unity TF Valve Kit	All

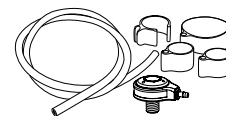

COMPONENTS

DUAL CHARGER KIT

The Dual Charger Kit is an optional kit that allows for simultaneous charging of any two combinations of Navii and Proprio Foot.

Part#	Description
CME10110	Power Supply and Cable Attachment



POWER SUPPLY

Part#	Description
CME50110	Power Supply w/Plug

