

# CP Guide

A Concept for the Orthotic Treatment of the Lower Extremity in Cerebral Palsy

9<sup>th</sup> edition



## Introduction

Thanks to its wide range of adjustment options in combination with the high spring forces, the NEURO SWING system ankle joint has now become the standard solution for the orthotic treatment of CP patients.

The continuous further development of the system joint has made it possible to considerably increase the treatment success for the patient with each new orthosis. This positive trend is especially visible in the large number of successfully completed treatments. In addition, the advantages of the NEURO SWING system ankle joint in the orthotic treatment of CP patients have also been confirmed by a wide range of international studies (see p. 48f.).

Thanks to its dynamic properties, the NEURO SWING system ankle joint is meeting with better and better acceptance among physiotherapists and physicians alike, since its use as a complement to qualified physiotherapy has now proven itself. This trend is a clear indication that a change in thinking was triggered by the introduction of the NEURO SWING system ankle joint and the publication of the CP Guide.

But, unfortunately, there are still different strategies being pursued in the field of CP treatments between the individual countries. The conservative treatment of CP patients is often held back from unfurling its true potential. With its simple classification of the pathological gait using the Amsterdam Gait Classification [Gru] and the treatment suggestions based on it, the CP Guide lays important foundations for optimal collaboration in the orthotic treatment of CP patients.

A new approach in the motor development of CP patients is the role of standing. A targeted stance training can promote motor development and also have a positive effect on walking. A dynamic AFO with NEURO SWING system ankle joint can be an integral part of such stance training. In order for you to keep an overview of your treatment options, we have listed all four models of the NEURO SWING system ankle joint for the first time in this guide.

We would like to thank all the readers who have contributed to the further development of the CP Guide with their suggestions and constructive criticisms since the first edition was published.

Your FIOR & GENTZ team

## Content

<b>Treatment Goal</b>	
What is Cerebral Palsy? _____	4
Treating CP in an Interdisciplinary Team _____	4
<b>Orthotic Treatment of CP</b>	
Standing and Walking _____	6
Conventional Orthoses _____	7
Disadvantages of Conventional Orthoses _____	9
Requirements for an Orthosis _____	9
<b>The NEURO SWING System Ankle Joint</b> _____	10
<b>Functional Advantages of an AFO with NEURO SWING</b>	
Precompressed Spring Units _____	14
Non-Precompressed Spring Units _____	15
<b>The NEURO SWING in a Dynamic AFO</b> _____	16
<b>Patient Classification</b>	
Gross Motor Skills and Mobility _____	24
Pathological Gait _____	25
<b>Treatment Suggestions</b>	
Treatment Suggestion for Gait Type 1 _____	26
Treatment Suggestion for Gait Type 2 _____	30
Treatment Suggestion for Gait Type 3 _____	34
Treatment Suggestion for Gait Type 4 _____	38
Treatment Suggestion for Gait Type 5 _____	42
<b>Studies on the Perspectives Presented in this Guide</b>	
from page _____	46
<b>Glossary</b>	
from page _____	50
<b>References</b>	
from page _____	58

## What is Cerebral Palsy?

In cerebral palsy, the impulses transmitted by the brain to the affected muscles are false and, as a result, the muscles are excessively, insufficiently or wrongly timed activated. This abnormal activation often leads to dysfunctions of some muscle groups, which normally result in a pathological gait [Gag1, p. 65]. Additionally, these muscular dysfunctions may be accompanied by spasticity [Pea, p. 89], which, in turn, changes the muscle tone in such a way that it may either worsen or improve gait.

## Treating CP in an Interdisciplinary Team

The overall goal of CP treatment is to enable the patient to stand and walk as unrestrictedly as possible. For that purpose, the interdisciplinary team consisting of physician, physiotherapist, occupational therapist, orthotist and biomechanic should pursue the same treatment concept and work closely with each other [Doe, p. 113ff.].

The first step of the treatment concept should be an immediate start of physiotherapy [Kra, p. 188]. The goal of this therapy is to treat insufficient muscle groups by establishing the right cerebral connections through motor impulses [Hor, p. 5-26] as well as strengthening individual muscle groups with specific muscle training. Both procedures should help bring the patient closer to a physiological gait.

In some CP patients, drug therapy, as with spasmolytics such as botulinum toxin [Mol, p. 363], and orthopaedic surgery to correct deformities [Gag2] are required along with physiotherapy.

To achieve the treatment goal, the physiological gait of a healthy person serves as orientation for the interdisciplinary team in the treatment of CP patients [Per, p. 9ff.].

Division of Physiological Gait into Different Phases According to

Jacquelin Perry

Term (Abbreviation)									
initial contact (IC)	loading response (LR)	early mid stance (MSt)	mid stance (MSt)	late mid stance (MSt)	terminal stance (TSt)	pre swing (PSw)	initial swing (ISw)	mid swing (MSw)	terminal swing (TSw)
Percentage of Stride									
0%	0-12%	12-31%			31-50%	50-62%	62-75%	75-87%	87-100%
Hip Angle									
20° flexion	20° flexion	10° flexion	neutral position	5° extension	20° extension	10° extension	15° flexion	25° flexion	20° flexion
Knee Angle									
0-3° flexion	15° flexion	12° flexion	8° flexion	5° flexion	0-5° flexion	40° flexion	60° flexion	25° flexion	0-2° extension
Ankle Angle									
neutral position	5° plantar flexion	neutral position	5° dorsiflexion	8° dorsiflexion	10° dorsiflexion	15° plantar flexion	5° plantar flexion	neutral position	neutral position

## Standing and Walking

Besides walking, standing plays an important role in the orthotic treatment of CP patients. The muscle groups activated when walking are also involved when standing and balance the body's centre of gravity above the supportive area. Because of these small balancing movements, standing still is not a merely static task, but a complex dynamic one. This particularity must be considered during the orthotic treatment.

In its motor development, a child starts with its first attempts at standing after about 9 ½ months and after about 10 months with its first attempts at walking. In a sense, standing is the transition from crawling to walking. A significant delay of these milestones can already indicate a cerebral palsy, although in most cases it is only diagnosed from 12 months on. An early and targeted stance training has a positive influence on the motor and gait development [Aud]. For that matter, a dynamic orthosis can support when standing and give the right motor impulses to the still young patients.

Milestones of a Child's Motor Development

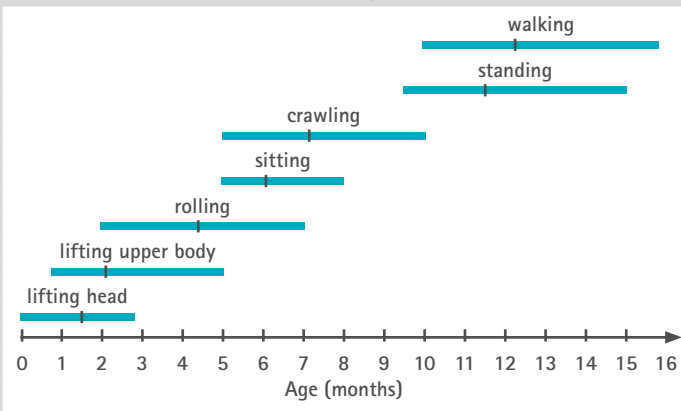

Mainly, orthoses should compensate for deficits of the joint-securing muscles and the resulting instability that is the reason for problems when standing and walking. Therefore, the first goal of an orthotic treatment is to dynamically bring the CP patient into an upright position. Patients who are not able to walk benefit as well from the dynamic stance training due to a variety of positive effects on the human organism [Pek]. However, selecting the right orthosis is essential for the treatment success.

## Conventional Orthoses

Depending on the severity and the characteristics of the clinical picture, the orthotic treatment of CP patients can be performed with a multitude of devices. They range from simple orthotic devices such as supramalleolar orthoses (SMOs) or sensorimotor inserts up to ankle-foot orthoses (AFOs) with or without an ankle joint. Since all these orthotic treatments have advantages and disadvantages, treating CP can have both positive and negative effects [Rom, p. 473].

” One orthosis may not be optimal to address all of the goals.

[Nov1, p. 330]

### Foot Orthoses

An easy and common way of treating CP patients are orthopaedic inserts with a sensorimotor insole. Such a sensorimotor insole can also be integrated into SMOs which are supramalleolar orthoses. SMOs slightly correct the foot position and activate the muscles. If the Achilles tendon area is not covered, they also possess dynamic features. In comparison to AFOs, however, they do not have any dorsiflexion-assist effect.

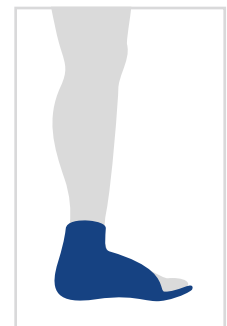

SMO

Up until now, AFOs are mostly produced without an ankle joint. They are divided into rigid/static AFOs and dynamic AFOs [Nov1, p. 330ff.]. Dynamic AFOs either have mechanical ankle joints or posterior leaf springs which allow movement in the anatomical ankle joint.

### Solid Orthoses

Solid AFOs (SAFOs) made of polypropylene or carbon do not allow any movement in the ankle. SAFOs are commonly used for patients with severe spasticity [Nov1, p. 336].

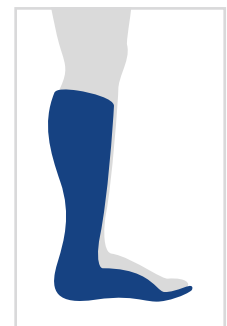

SAFO

The so-called floor reaction AFO (FRAFO) with an anterior shell also blocks any movement of the anatomical ankle joint. A FRAFO is either made of polypropylene or carbon. The anterior shell enables a knee extension in terminal stance. However, this is contraindicated in patients with a hyperextended knee.

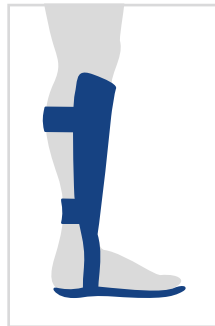

FRAFO

## Orthoses with Ankle Joint

AFOs with an ankle joint (hinged AFOs), which allow movement in the anatomical ankle joint with a defined pivot point and range of motion, are used less commonly. However, in most cases, hinged AFOs only possess elastomer spring joints or ordinary joints with coil springs. The weak or non existing spring effect of these joints as well as the non existing dorsiflexion stop can lead to the development of crouch gait [Nov1, p. 345]. Therefore, hinged AFOs have barely been used in the orthotic treatment of CP patients so far.

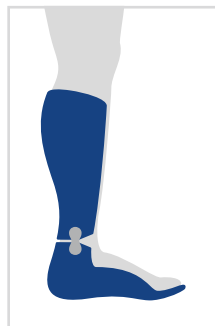

Hinged AFO

## Orthoses with Posterior Leaf Spring

For some time now, AFOs with a spring effect, so-called posterior-leaf-spring AFOs, have been used. The strong spring effect is achieved using carbon springs, whereas this effect is minimal with similar AFOs made of polypropylene. The disadvantage is that these orthoses have no defined pivot point, no defined or adjustable range of motion and no adjustable alignment. A passive plantar flexion is completely prevented.



Posterior-leaf-spring AFO

## Disadvantages of Conventional Orthoses

Each of the listed orthoses provides not only advantages but also disadvantages. That means that each treatment with a conventional orthosis can result in a successful therapy, but can also have a negative effect on it. Mainly, two characteristics affect the therapy goal negatively:

### 1. Lack of Adjustment Options

Depending on the patient's pathological gait, the physician's requirements and the goal of physiotherapy, the orthotist must produce an orthosis that provides the required lever effect [Owe, p. 262]. However, the construction of an effective orthosis has not been possible until now due to a lack of adjustment options. With the mentioned orthoses, an optimal adaptation to the pathological gait of the patient is therefore only possible to a limited extent.

### 2. Limited Plantar Flexion

Almost all of the listed constructions restrict the physiological plantar flexion. Thus, no ideal compromise between dorsiflexion-assist effect and heel rocker can be found. Qualified physiotherapy uses the very important heel lever. By doing so, the right cerebral connections are established through motor impulses [Hor, p. 5-26] and individual muscle groups are strengthened with special muscle training.

## Requirements for an Orthosis

A modern orthosis concept is expected to be optimally adjustable to the patient's needs and the course of therapy. It should also allow for a dynamic stability while both standing and walking. Only then can the overall goal of an orthosis be achieved: a physiological gait.

Therefore, all orthoses for CP patients should be constructed with an adjustable ankle joint. It is absolutely necessary to be able to adjust the orthosis alignment, since the position of the patient's foot when producing the cast model differs from its position under load with the orthosis. Thanks to an adjustable range of motion and a variable spring force, the orthotist can react to changes in the gait that may occur during the course of therapy without much difficulty.

The adjustable NEURO SWING system ankle joint has been developed for that exact reason.

To adapt the orthosis optimally to the patient's requirements, the NEURO SWING system ankle joint has three adjustment options. All adjustments can be made separately. They do not influence each other:

## 1. Adjustable Alignment

Thanks to the adjustable alignment of the NEURO SWING system ankle joint, the orthosis can be individually adjusted to the patient's pathological gait. Should the gait change, a quick response by an adjustment modification and tuning is easily possible.

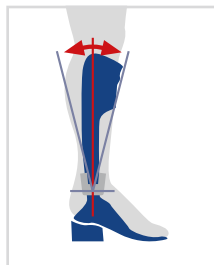

Adjustable alignment

## 2. Adjustable Range of Motion

In the early rehabilitation stages following a surgery, it may be necessary to partially or completely disable the range of motion of an orthosis and to only enable it at a later stage of therapy. Thanks to the motion limiting screw, which is integrated in the NEURO SWING system ankle joint, the pre-defined range of motion in plantar flexion and dorsiflexion can be completely blocked and gradually released again.

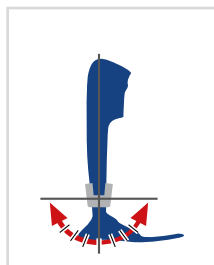

Adjustable range of motion

## 3. Variable Spring Force

The spring force in plantar flexion and dorsiflexion can be individually adjusted to the patient's needs thanks to the exchangeable, precompressed spring units. A total of five different spring units is available for the NEURO SWING system ankle joint, ranging in strength from normal to extra strong and with a range of motion from 15° to 5°.

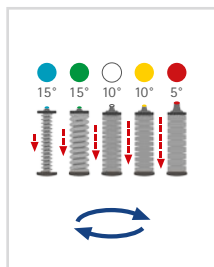

Variable spring force

The NEURO SWING system ankle joint is available in four models, each in up to five system widths. In order to be able to select the suitable system width according to the determined patient data, please use the FIOR & GENTZ Orthosis Configurator.



[www.orthosis-configurator.com](http://www.orthosis-configurator.com)



## NEURO SWING



With its adjustable alignment, adjustable range of motion and the exchangeable, precompressed spring units, the NEURO SWING is the ideal system joint for a flexible treatment. Another plus is the plug + go modularity, which allows a conversion to any other system joint in the plug + go series in just a few simple steps.

## NEURO SWING 2



With the NEURO SWING 2, the alignment, range of motion and spring force are also adjustable. In addition, it has an integrated noise reduction and is therefore the ideal choice for people who appreciate silent locomotion. Like the NEURO SWING, it is part of the plug + go series and can be converted if required.

## NEURO SWING Carbon

The NEURO SWING Carbon is the waterproof NEURO SWING model. With its adjustable alignment and exchangeable, precompressed spring units it offers the same advantages as the NEURO SWING, but can also be used in wet and outdoor areas thanks to the carbon fibre reinforced joint case. The range of motion of the NEURO SWING Carbon is not adjustable.



## NEURO HiSWING

With the NEURO HiSWING, the first hydraulic ankle joint has been developed. The ankle joint angle can be adjusted by the patient himself using the hydraulic mechanism, which makes it possible to climb stairs and hike in uneven terrain with less effort. The orthosis can easily be adapted to different heel heights and offers more comfort when sitting.

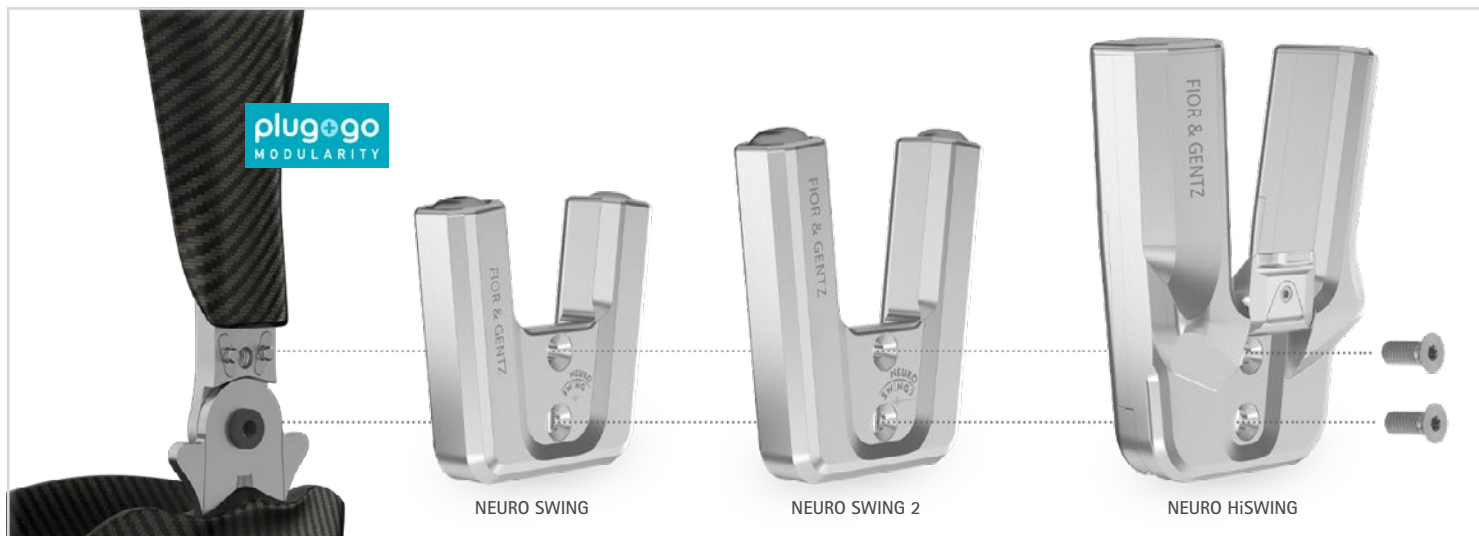

## Precompressed Spring Units

In order to bring a body into a stable balance, the forefoot lever must be activated. In case of a weakness of the plantar flexors, the dynamic activation of the forefoot lever is enabled, which creates a knee-extending moment and guarantees knee stability.

### Effects on Stance

The precompressed spring units with a high basic resistance in the NEURO SWING system ankle joint provide dynamic balance and stability. This allows for a secure stance. Since no medical devices other than the orthosis are required, the hands are free for everyday tasks.

### Effects on Gait in Terminal Stance

- heel lift
- body's centre of gravity at physiological height
- normal knee flexion on the contralateral side
- improved energy consumption during walking

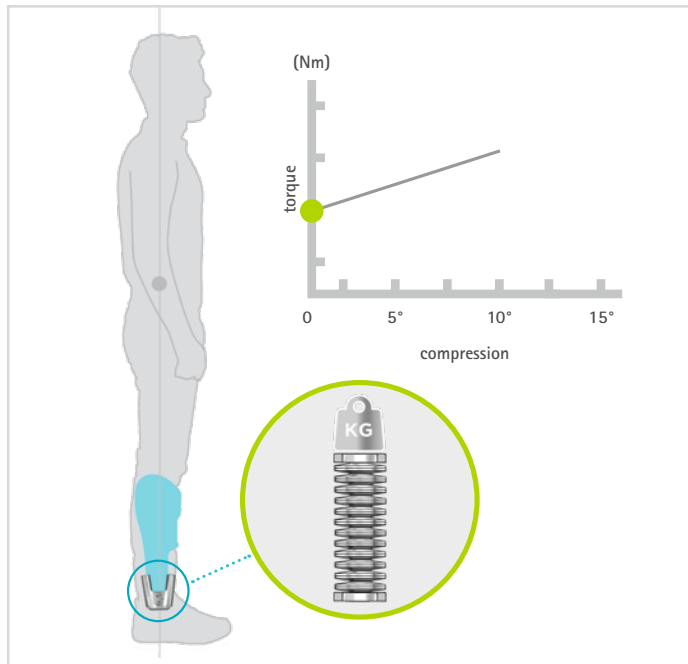

## Non-Precompressed Spring Units

Common coil springs of conventional ankle joints must be heavily compressed to generate resistance. In case of a weakness of the plantar flexors, the activation of the forefoot lever is not possible causing the absence of a knee-extending moment and a reduced knee stability.

### Effects on Stance





The nonexistent basic resistance due to the lack of precompression leads to a yielding of the spring when loaded during stance and, due to the missing security, to an unstable stance. This requires the use of medical devices such as crutches or walkers. The hands are therefore needed for support.

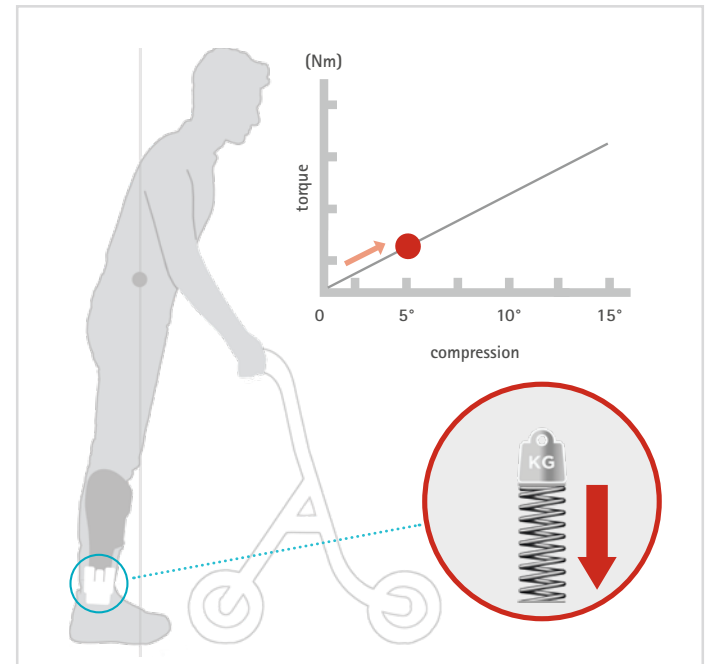

### Effects on Gait in Terminal Stance

- no heel lift
- body's centre of gravity too low
- excessive knee flexion on the contralateral leg side
- energy consumption during walking too high

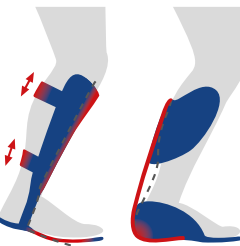

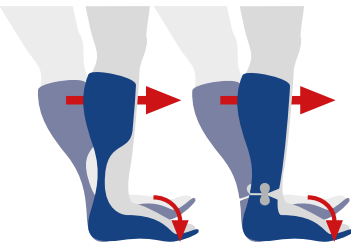
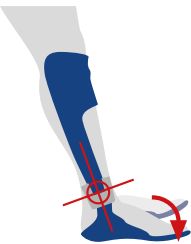

Disadvantages of Existing AFOs	Properties of the NEURO SWING	Description
 <p data-bbox="124 751 354 775">no adjustable alignment</p>	 <p data-bbox="512 751 713 775">adjustable alignment</p>	<p data-bbox="847 397 1062 421"><b>Adjustable Alignment</b></p> <p data-bbox="847 429 1490 775">Since the orthosis must be aligned in such a way that it provides the required lever effect [Nov2, p. 488ff.], it is necessary to use an adjustable ankle joint. This is the only way to adjust the orthosis precisely to the CP patient's pathological gait and to react flexibly to changes. In rigid AFOs without an ankle joint, the alignment can only be adjusted by inserting wedges, also known as tuning [Owe, p. 257]. However, increasing the pitch also enlarges the dorsiflexion, the lower leg incline, the hip and knee flexion and the knee flexion moment in mid stance (see p. 46ff.). With the NEURO SWING system ankle joint, the alignment of the orthosis can be altered independently of the pitch.</p>
 <p data-bbox="134 1331 343 1355">no defined pivot point</p>	 <p data-bbox="520 1331 703 1355">defined pivot point</p>	<p data-bbox="847 1007 1038 1031"><b>Defined Pivot Point</b></p> <p data-bbox="847 1038 1490 1355">Some orthoses allow movement between foot and lower leg even without an ankle joint. However, these orthoses only allow insufficient movement of the anatomical ankle joint which can result in muscular atrophies [Goe, p. 98f.]. Furthermore, the orthosis shells shift unintentionally on the CP patient's leg and can cause skin irritations. The defined pivot point supports qualified physiotherapy in treating insufficient muscle groups by establishing the right cerebral connections through motor impulses [Hor, p. 5-26] and strengthening individual muscle groups with specific muscle training.</p>

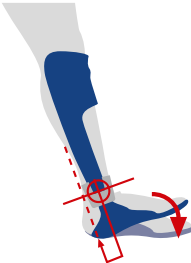
Disadvantages of Existing AFOs	Properties of the NEURO SWING	Description
 <p data-bbox="129 751 352 775">plantar flexion blocked</p>	 <p data-bbox="501 751 724 775">plantar flexion possible</p>	<p data-bbox="847 432 999 456"><b>Plantar Flexion</b></p> <p data-bbox="847 464 1490 520">Due to the blocked plantar flexion, an excessive torque is applied to the lower leg and transmitted to the knee.</p> <p data-bbox="847 528 1490 616">This results in an enormous stress on the m. quadriceps (comparable to walking with a ski boot), although CP patients mostly have an insufficient m. quadriceps [Goe, p. 134ff.; Per, p. 195].</p> <p data-bbox="847 624 1490 775">Qualified physiotherapy uses the passive plantar flexion to treat insufficient muscle groups. By doing so, the right cerebral connections are established through motor impulses [Hor, p. 5-26] and individual muscle groups are strengthened with specific muscle training. This makes it possible to counteract the advancing muscle atrophy [Goe, p. 98ff.].</p>
 <p data-bbox="172 1329 308 1353">no heel rocker</p>	 <p data-bbox="560 1329 663 1353">heel rocker</p>	<p data-bbox="847 975 967 999"><b>Heel Rocker</b></p> <p data-bbox="847 1007 1490 1158">The anatomical pivot point creates a lever arm at the hindfoot which runs from the point of heel strike through the calcaneus to the ankle. At initial contact, the body weight triggers a passive foot dropping via this lever which is controlled by the eccentric work of the m. tibialis anterior.</p> <p data-bbox="847 1166 1490 1382">Other orthoses such as the posterior-leaf-spring AFOs do not allow this function. With these orthoses, foot dropping is only possible actively against muscle work, but this does not correspond to the physiological movement. The NEURO SWING system ankle joint allows passive foot dropping by means of the defined pivot point and the range of motion adjustable in plantar flexion. This movement is controlled by the posterior spring unit.</p>

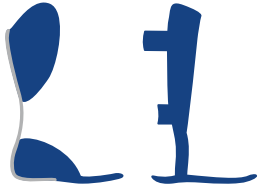
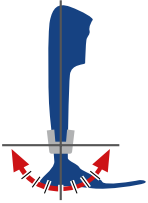
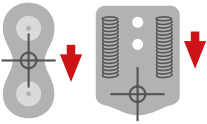
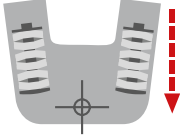
Disadvantages of Existing AFOs	Properties of the NEURO SWING	Description
 <p data-bbox="92 746 384 775">no adjustable range of motion</p>	 <p data-bbox="483 746 743 775">adjustable range of motion</p>	<p data-bbox="847 395 1126 424"><b>Adjustable Range of Motion</b></p> <p data-bbox="847 427 1490 552">After surgery, it may be necessary to limit the range of motion of an orthosis partially or completely and only allow it again later in the course of therapy. Thus, an ankle joint with individually adjustable range of motion must be mounted to an AFO.</p> <p data-bbox="847 555 1490 775">Using an adjustable ankle joint in a static AFO: Some CP patients are treated with spasmolytics such as botulinum toxin. The muscles are paralysed temporarily. If it is used too often, the muscle strength can change. In this case, a static AFO can provide the greatest possible lever effect [Nov2, p. 488ff]. Even when a general success cannot be expected during physiotherapy or the foot is severely deformed, it also makes sense to treat CP patients with a static AFO.</p>
<p data-bbox="140 1011 341 1066">elastomer spring and coil spring joint</p>  <p data-bbox="161 1331 316 1359">low spring force</p>	<p data-bbox="555 1040 671 1069">disc springs</p>  <p data-bbox="531 1331 695 1359">high spring force</p>	<p data-bbox="847 975 975 1003"><b>Spring Force</b></p> <p data-bbox="847 1007 1490 1323">The pathological gait of some CP patients requires very high spring forces. With the NEURO SWING system ankle joint, these spring forces are achieved with disc springs stacked into compact spring units. The spring units store the energy brought in by the body weight. If this energy is released in pre swing, it supports the push off [Nov1, p. 333]. An AFO with NEURO SWING system ankle joint achieves this effect at least as well as a posterior-leaf-spring AFO. For CP patients with excessive knee flexion in mid stance, the high spring forces of the red and yellow spring unit improve the joint angles and the energy return when walking (see p. 46ff.).</p> <p data-bbox="847 1326 1490 1386">Common constructions such as elastomer spring or coil spring joints cannot nearly achieve this effect.</p>

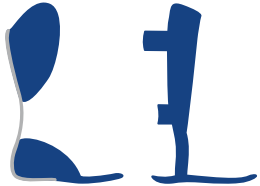
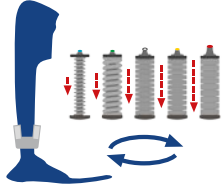
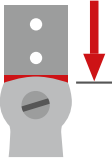
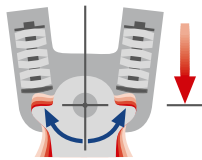
Disadvantages of Existing AFOs	Properties of the NEURO SWING	Description
 <p data-bbox="124 751 352 775">no variable spring force</p>	<p data-bbox="488 464 735 488">exchangeable spring units</p>  <p data-bbox="512 751 703 775">variable spring force</p>	<p data-bbox="847 432 1054 456"><b>Variable Spring Force</b></p> <p data-bbox="847 464 1485 743">The spring force in plantar flexion and dorsiflexion can be individually and easily adjusted to the patient's pathological gait by using spring units of different strength. This makes it possible to determine the optimal spring force with which CP patients can reduce the energy required for walking. Furthermore, the separate adjustability of the spring force in plantar flexion and dorsiflexion can result in a perceivable and measurable improvement in gait (see p. 46ff.). In AFOs without ankle joint, the spring force can only be changed to a limited extent.</p>
 <p data-bbox="188 1334 288 1358">hard stops</p>	 <p data-bbox="560 1334 655 1358">soft stops</p>	<p data-bbox="847 1134 951 1158"><b>Soft Stops</b></p> <p data-bbox="847 1166 1485 1222">The integrated disc springs guarantee a soft stop that counteracts the development or worsening of spasticity.</p>

To achieve the desired treatment goal, the interdisciplinary team needs to find a common basis for assessing the different characteristics of cerebral palsy. This basis can be created by classifying CP patients according to determined criteria, thereby establishing a classification.

## Gross Motor Skills and Mobility

The Gross Motor Function Classification System (GMFCS) helps to assess gross motor skills of CP patients in activities of daily living and to make a prognosis of their further development [Rus]. It gives priority to locomotion, taking required assistance into account, and classifies patients according to their age into five levels [Öun, p. 151ff.].

The Functional Mobility Scale (FMS) divides CP patients into six groups, according to their mobility. The devices used for the locomotion and the distance covered with them are included in the assessment [Gra, p. 515].

## Pathological Gait

In 2001, Rodda and Graham analysed and divided patients with spastic hemiplegia and diplegia into four gait types using video recording and taking gait pattern and posture into account [Rod, p. 98ff.]. Currently, this classification is the most used in clinical practice.

In addition to this classification, there is the Amsterdam Gait Classification, which was developed at the VU University Medical Center in Amsterdam especially for CP patients. It classifies five types of gait according to their knee position and foot contact in mid stance (see illustration below). A description of the physiological position in mid stance is given on page 4 and 5. The Amsterdam Gait Classification is equally suitable for patients that are affected either unilaterally or bilaterally [Gru, p. 30]. Therefore, it can be used optimally as classification for a standardised orthotic treatment. The Amsterdam Gait Classification makes it possible to quickly classify CP patients according to their gait. This facilitates the interdisciplinary communication as well as the selection of the right treatment method. Furthermore, it contributes to standardising orthotic treatments and controlling their quality.

The books by Perry and Götz-Neumann present an easy-to-understand overview about the clinical gait analysis [Per; Goe].

### Gait Types According to the Amsterdam Gait Classification

Gait Types	Type 1	Type 2	Type 3	Type 4	Type 5
Knee	normal	hyperextended	hyperextended	flexed	flexed
Foot Contact	complete	complete	incomplete	incomplete	complete
Treatment	see p. 26-29	see p. 30-33	see p. 34-37	see p. 38-41	see p. 42-45

Illustration of gait types in mid stance

## Treatment Suggestion for Gait Type 1

### Pathological Gait

An insufficient m. tibialis anterior and a mostly shortened m. gastrocnemius are typical for gait type 1. This muscular deficiency causes a foot drop, which in turn, causes an impaired dorsiflexion in swing phase.

In mid stance, the foot is plantigrade and the knee is in a physiological position [Bec, p. 1, p. 5f.].

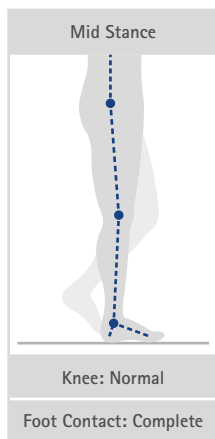

### Recommended Orthosis

Dynamic AFO with high anterior shell, long and partially flexible foot piece (rigid sole with flexible toe area) and NEURO CLASSIC-SPRING system ankle joint.

The NEURO CLASSIC-SPRING system ankle joint comes with an integrated coil spring with a normal spring force and 20° range of motion.

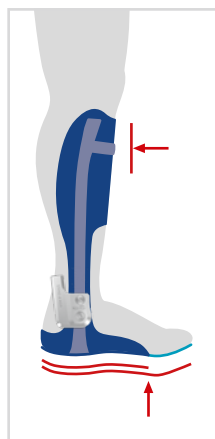

### Adjustment Options of the NEURO CLASSIC-SPRING System Ankle Joint

A NEURO CLASSIC-SPRING system ankle joint with plug + go modularity can be converted, among others, into a NEURO SWING system ankle joint by exchanging the functional unit.

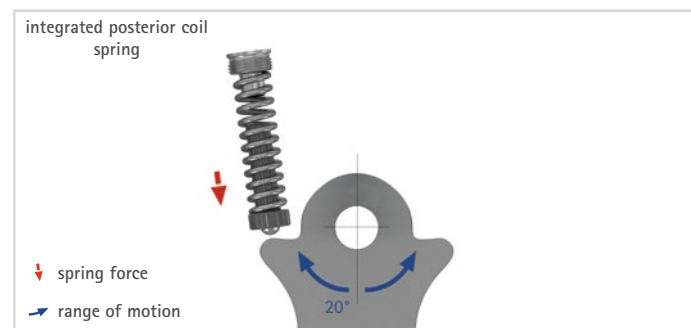

### Effect on Foot Deformities

There are a number of different methods which can be applied to improve the patient's foot deformity and which can be combined with an orthosis:

Both a ring-shaped foot holder and a so-called inner shoe can be integrated in the orthosis, thereby additionally supporting its function in a positive way.

Sensorimotor elements represent another alternative. They can be adhered to an inner shoe or the foot piece of the orthosis or modelled during the production of the positive cast (see picture).



## Treatment Suggestion for Gait Type 1

### Present Orthotic Treatment Options



Due to the small deviations from the physiological gait, CP patients of this gait type have been treated almost exclusively with simple devices until now. This includes ankle-high shoes, supramalleolar orthoses (SMOs) or sensorimotor inserts [Gru, p. 33; Nov1, p. 331]. However, the dorsiflexion-assist effect of these devices, which is only minimal, must be regarded critically. Moreover, maintained physiological movements can be restricted.

### Effect of the Orthosis

- Initial contact and loading response: The normal spring force of the NEURO CLASSIC-SPRING system ankle joint is sufficient to keep the foot in a neutral position during swing phase, thus ensuring that the heel touches the ground at initial contact. At the same time, the defined pivot point and the range of motion of 20° allow a passive plantar flexion. This replaces the eccentric work of the pretibial muscles and allows the heel rocker. The foot is lowered in a controlled manner against the force of the integrated posterior coil spring.
- Mid stance: The physiological knee extension is not influenced thanks to the free dorsiflexion stop of the NEURO CLASSIC-SPRING system ankle joint.
- Terminal stance: The physiological knee extension and heel lift are not influenced thanks to the free dorsiflexion stop of the NEURO CLASSIC-SPRING system ankle joint.
- Pre swing: A physiological push off is possible due to the range of motion of the integrated posterior coil spring of 20°.
- Initial swing to terminal swing: The integrated posterior coil spring keeps the foot in a neutral position. The CP patient can walk without stumbling and, therefore, torso and hip are relieved.

Additionally, it is possible to integrate in the recommended orthosis elements of the above-mentioned simple devices that support the treatment such as sensorimotor insoles.

## Treatment Suggestion for Gait Type 2

### Pathological Gait

An insufficient m. tibialis anterior and, additionally, a wrong activation of the m. triceps surae are typical for gait type 2.

In mid stance, the foot is plantigrade and the knee remains hyperextended [Bec, p. 146].

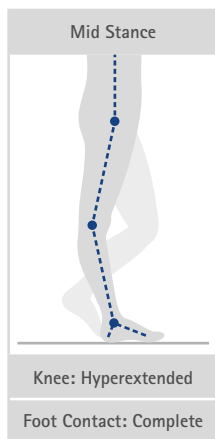

### Adjustment Options of the NEURO SWING System Ankle Joint

Individual adjustment to the pathological gait by:

- exchangeable spring units;
- adjustable alignment;
- adjustable range of motion.

All three adjustment options can be chosen separately. They do not influence each other.

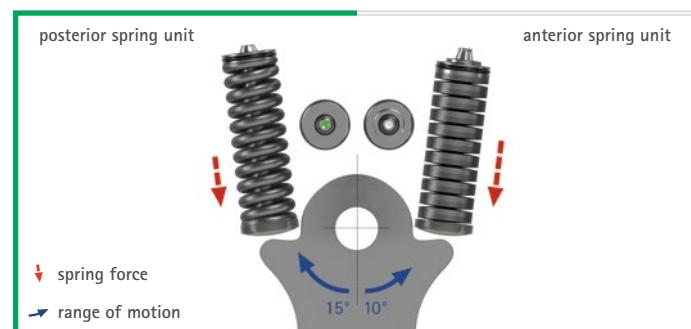

### Recommended Orthosis

Dynamic AFO with high anterior shell, long and partially flexible foot piece (rigid sole with flexible toe area) and NEURO SWING system ankle joint.

Why an anterior shell? Please read the info box on page 33.

### Spring units to be used:

- posterior: green marking (medium spring force, max. 15° range of motion)
- anterior: white marking (strong spring force, max. 10° range of motion)

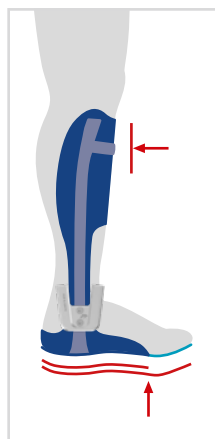

### Effect on Foot Deformities

There are a number of different methods which can be applied to improve the patient's foot deformity and which can be combined with an orthosis:

Both a ring-shaped foot holder and a so-called inner shoe can be integrated in the orthosis, thereby additionally supporting its function in a positive way.

Sensorimotor elements represent another alternative. They can be adhered to an inner shoe or the foot piece of the orthosis or modelled during the production of the positive cast (see picture).





## Treatment Suggestion for Gait Type 2

### Present Orthotic Treatment Options

Until now, almost all CP patients of this gait type have been treated with hinged AFOs which only allow dorsiflexion. Due to this construction, the foot is kept in neutral position or in slight dorsiflexion and the plantar flexion is blocked [Gru, p. 33]. Between initial contact and loading response, an excessive torque is applied to the lower leg and transmitted to the knee. This results in an enormous stress on the m. quadriceps (comparable to walking with a ski boot) [Goe, p. 134ff.; Per, p. 195].

### Effect of the Orthosis

- Initial contact and loading response: The strength of the posterior spring unit of the NEURO SWING system ankle joint is sufficient to keep the foot in neutral position, thus ensuring that the heel touches the ground at initial contact. It enables a passive plantar flexion since it allows the eccentric work of the pretibial muscles. Therefore, the heel rocker is actively supported and no excessive torque is applied to the lower leg. The foot is lowered in a controlled manner against the spring force of the posterior spring unit. The passive plantar flexion prevents an early activation of the m. gastrocnemius. If the recommended, medium posterior spring unit (green marking) restricts the heel rocker too much, it must be exchanged for the normal spring unit (blue marking).

- Mid stance: The anterior spring unit in the NEURO SWING system ankle joint and the anterior shell prevent the hyperextension of the knee.
- Terminal stance: Due to the strong anterior spring unit and the anterior shell, a physiological lifting of the heel can be achieved. If lifting the heel is not possible, the strong anterior spring unit (white marking) must be exchanged for a very strong spring unit (yellow marking).
- Pre swing: The anterior spring unit brings the foot in neutral position from pre swing to mid swing. The CP patient can walk without stumbling and, therefore, torso and hip are relieved.



#### Why an anterior shell?

An orthosis with high anterior shell can only be produced thanks to the high spring forces of the applied spring units. Due to the anterior shell, the patient's initial reflex to support themselves to achieve stability is changed. By pressing their body weight with the tibia against the anterior shell, they gain stability in stance. This prevents an increasing knee hyperextension and the development of contractures in the anatomical ankle joint.

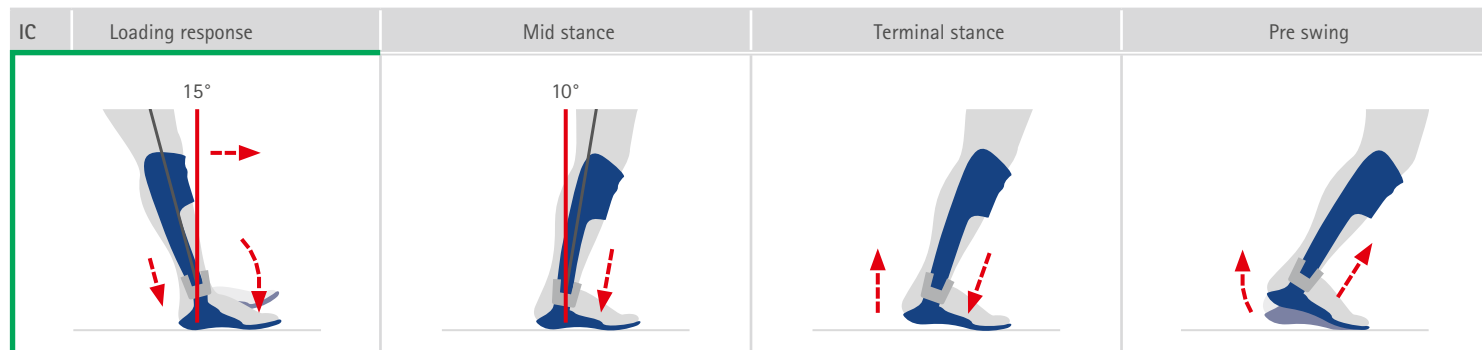

## Treatment Suggestion for Gait Type 3

### Pathological Gait

An insufficient m. tibialis anterior and a too early or too early and excessive activation of the m. triceps surae are typical for gait type 3.

In mid stance, the load remains on the forefoot and the foot is not plantigrade. The knee remains hyperextended [Bec, p. 146].

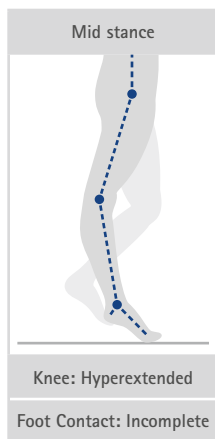

### Adjustment Options of the NEURO SWING System Ankle Joint

Individual adjustment to the pathological gait by:

- exchangeable spring units;
- adjustable alignment;
- adjustable range of motion.

All three adjustment options can be chosen separately. They do not influence each other.

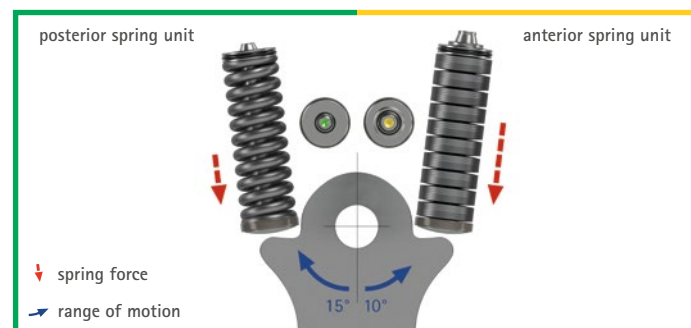

### Recommended Orthosis

Dynamic AFO with high anterior shell, long and partially flexible foot piece (rigid sole with flexible toe area) and NEURO SWING system ankle joint.

Why an anterior shell? Please read the info box on page 37.

### Spring units to be used:

- posterior: green marking (medium spring force, max. 15° range of motion)
- anterior: yellow marking (very strong spring force, max. 10° range of motion)

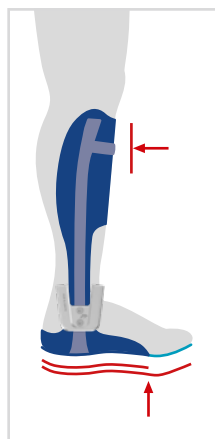

### Effect on Foot Deformities

There are a number of different methods which can be applied to improve the patient's foot deformity and which can be combined with an orthosis:

Both a ring-shaped foot holder and a so-called inner shoe can be integrated in the orthosis, thereby additionally supporting its function in a positive way.

Sensorimotor elements represent another alternative. They can be adhered to an inner shoe or the foot piece of the orthosis or modelled during the production of the positive cast (see picture).



## Treatment Suggestion for Gait Type 3

### Present Orthotic Treatment Options

Until now, CP patients of this gait type have been treated with SAFOs with posterior shell. They keep the foot in neutral position or in slight dorsiflexion [Gru, p. 33]. However, their rigid construction blocks any plantar flexion. Between initial contact and loading response, an excessive torque is applied to the lower leg and transmitted to the knee. This results in an enormous stress on the m. quadriceps (comparable to walking with a ski boot) [Goe, p. 134ff.; Per, p. 195]. Additionally, due to the unfavourable construction with a posterior shell, the CP patient's reflex to support the calf on the shell in order to gain stability in stance is enhanced. This provokes a hyperextension of the knee.

### Effect of the Orthosis

- Initial contact and loading response: The strength of the posterior spring unit of the NEURO SWING system ankle joint is sufficient to keep the foot in neutral position, thus ensuring that the heel touches the ground at initial contact. It enables a passive plantar flexion since it allows the eccentric work of the pretibial muscles. Therefore, the heel rocker is actively supported and no excessive torque is applied to the lower leg. The foot is lowered in a controlled manner against the force of the posterior spring unit. The passive plantar flexion prevents an early activation of the m. gastrocnemius.

- Mid stance: The tibial progression causes the dorsiflexion in the ankle which, in turn, preloads the anterior spring unit.
- Terminal stance: The spring unit is preloaded up to the adjusted range of motion. The energy brought in by the body weight is stored in the anterior spring unit.
- Pre swing: From terminal stance to pre swing, the anterior spring unit releases the stored energy that assists the push off.



#### Why an anterior shell?

An orthosis with high anterior shell can only be produced thanks to the high spring forces of the applied spring units. Due to the anterior shell, the patient's initial reflex to support themselves to achieve stability is changed. By pressing their body weight with the tibia against the anterior shell, they gain stability in stance. This prevents an increasing knee hyperextension and the development of contractures in the anatomical ankle joint.

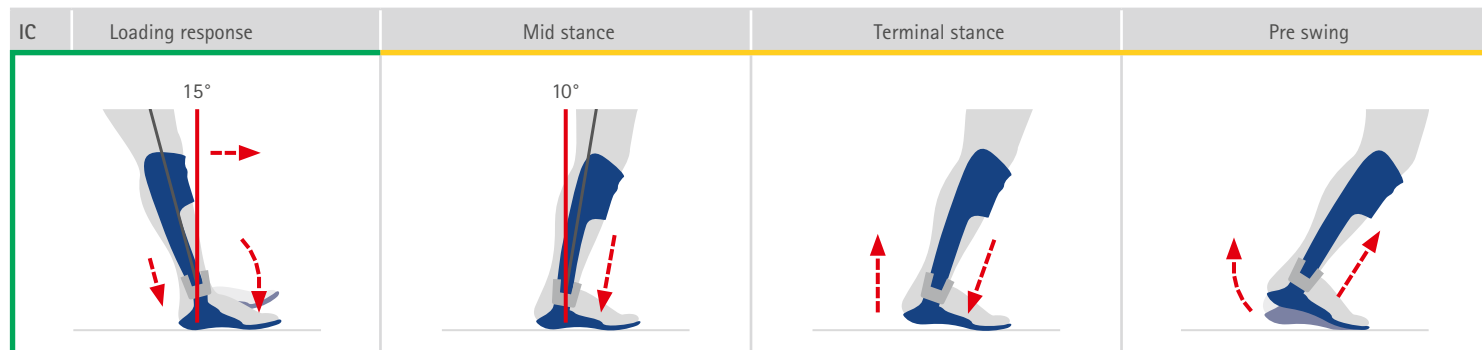

## Treatment Suggestion for Gait Type 4

### Pathological Gait

An excessive activation of the ischiocrural muscles accompanied by a wrong activation of the m. gastrocnemius or m. psoas major are typical for gait type 4.

In mid stance, the load remains on the forefoot and the foot is not plantigrade. Additionally, knee and hip flexion remain [Bec, p. 46].

The patient also spends a lot of energy when walking [Bre, p. 102].

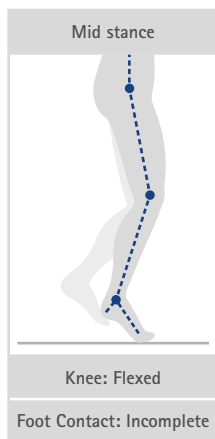

### Adjustment Options of the NEURO SWING System Ankle Joint

Individual adjustment to the pathological gait by:

- exchangeable spring units;
- adjustable alignment;
- adjustable range of motion.

All three adjustment options can be chosen separately. They do not influence each other.

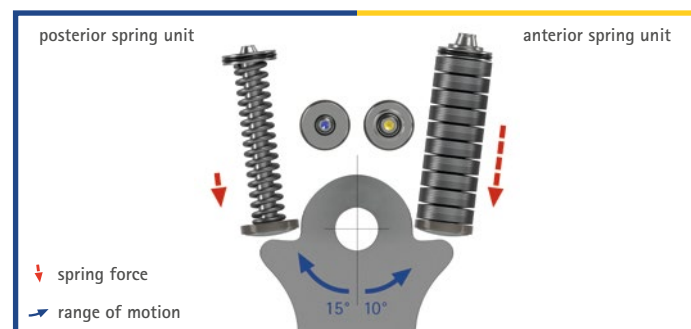

### Recommended Orthosis

Dynamic AFO with high anterior shell, long and rigid foot piece with toe spring and NEURO SWING system ankle joint.

Why a toe spring? Please read the info box on page 41.

### Spring units to be used:

- posterior: blue marking (normal spring force, max. 15° range of motion)
- anterior: yellow marking (very strong spring force, max. 10° range of motion)

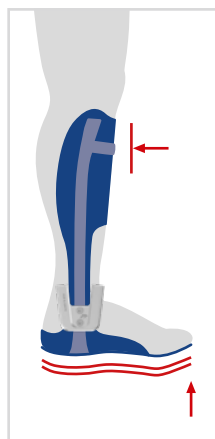

### Effect on Foot Deformities

There are a number of different methods which can be applied to improve the patient's foot deformity and which can be combined with an orthosis:

Both a ring-shaped foot holder and a so-called inner shoe can be integrated in the orthosis, thereby additionally supporting its function in a positive way.

Sensorimotor elements represent another alternative. They can be adhered to an inner shoe or the foot piece of the orthosis or modelled during the production of the positive cast (see picture).



## Treatment Suggestion for Gait Type 4

### Present Orthotic Treatment Options

Until now, CP patients of this gait type have been treated with SAFOs with posterior shell and rigid sole. They keep the foot in neutral position or in slight dorsiflexion. However, their rigid construction blocks any plantar flexion. Between initial contact and loading response, an excessive torque is applied to the lower leg and transmitted to the knee. This results in an enormous stress on the m. quadriceps (comparable to walking with a ski boot) [Goe, p. 134ff.; Per, p. 195].

### Effect of the Orthosis

- Initial contact and loading response: If the CP patient has no plantar flexion contracture, the strength of the posterior spring unit of the NEURO SWING system ankle joint is sufficient to keep the foot in neutral position, thus ensuring that the heel touches the ground at initial contact. It enables a passive plantar flexion since it allows the eccentric work of the pretibial muscles. Therefore, the heel rocker is actively supported and no excessive torque is applied to the lower leg. The foot is lowered in a controlled manner against the force of the posterior spring unit. If the recommended, normal spring unit (blue marking) is too weak to keep the foot in neutral position in terminal swing because of an existing plantar flexion contracture, it must be exchanged for a stronger spring unit.

- Mid stance: The anterior spring unit creates in combination with the long and rigid foot piece and the anterior shell a knee extension moment. This straightens the CP patient up and significantly improves the excessive knee flexion and lower leg incline (see p. 46f.). Furthermore, the patient gains stability in stance. If the very strong spring unit (yellow marking) is not strong enough, it can be exchanged for the extra strong spring unit (red marking).
- Terminal stance: From mid stance to terminal stance, the anterior spring unit is preloaded up to the adjusted range of motion and stores the energy brought in by the body weight.
- Pre swing: From terminal stance to pre swing, the anterior spring unit releases the energy that assists the push off. Due to the construction of the orthosis and the supportive effect of the spring unit, the patient spends less energy when walking [see p. 46f.].



### Why a toe spring?

When modifying the positive cast, a suitable toe spring should be taken into account. At rigid foot pieces, a toe spring is necessary to allow a heel-to-toe movement via the metatarsophalangeal joints (3. rocker) and to give more stability to the patient thanks to the forefoot contact in pre swing.

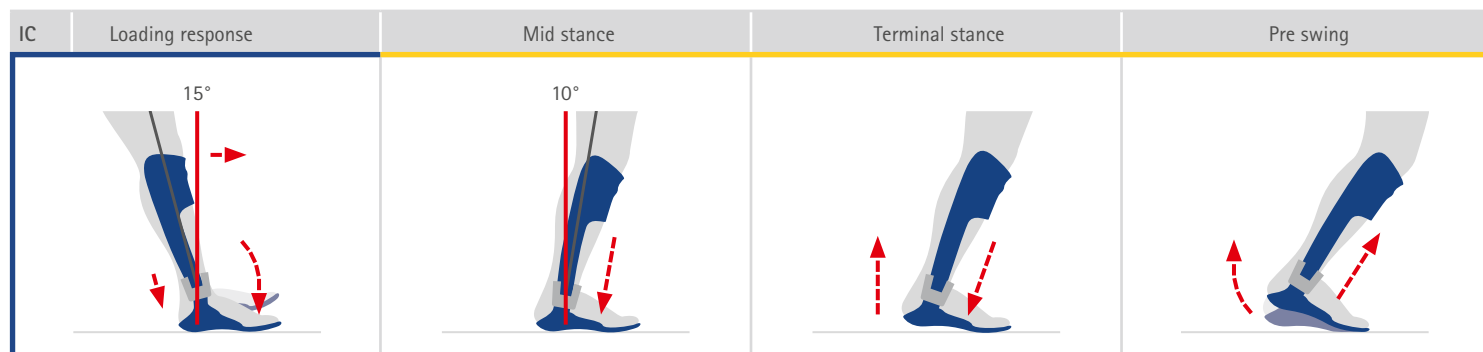

## Treatment Suggestion for Gait Type 5

### Pathological Gait

An excessive activation of the ischiocrural muscles accompanied by an insufficient activation of the m. gastrocnemius or a wrong activation of the m. psoas major are typical for gait type 5. This leads to an increased knee and hip flexion in mid stance. Furthermore, the foot is plantigrade [Bec, p. 146].

The patient also spends a lot of energy when walking [Bre, p. 102].

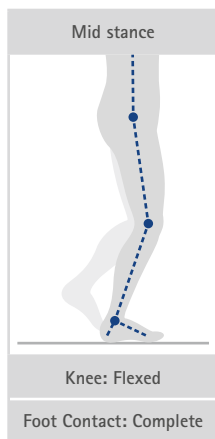

### Adjustment Options of the NEURO SWING System Ankle Joint

Individual adjustment to the pathological gait by:

- exchangeable spring units;
- adjustable alignment;
- adjustable range of motion.

All three adjustment options can be chosen separately. They do not influence each other.

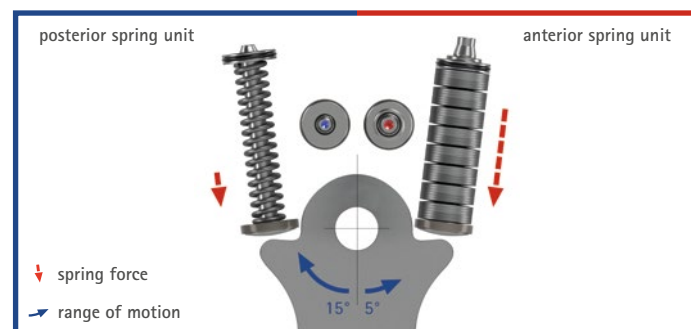

### Recommended Orthosis

Dynamic AFO with high anterior shell, long and rigid foot piece with toe spring and NEURO SWING system ankle joint.

Why a toe spring? Please read the info box on page 45.

#### Spring units to be used:

- posterior: blue marking (normal spring force, max. 15° range of motion)
- anterior: red marking (extra strong spring force, max. 5° range of motion)

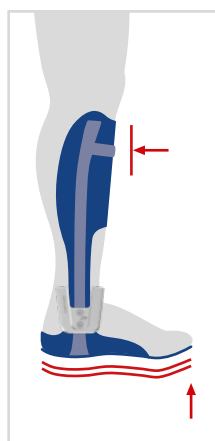

### Effect on Foot Deformities

There are a number of different methods which can be applied to improve the patient's foot deformity and which can be combined with an orthosis:

Both a ring-shaped foot holder and a so-called inner shoe can be integrated in the orthosis, thereby additionally supporting its function in a positive way.

Sensorimotor elements represent another alternative. They can be adhered to an inner shoe or the foot piece of the orthosis or modelled during the production of the positive cast (see picture).



## Treatment Suggestion for Gait Type 5

### Present Orthotic Treatment Options

Until now, CP patients of this gait type have been treated with FRAFOs with anterior shell and rigid sole. They keep the foot in neutral position or in slight dorsiflexion. The anterior shell and the rigid sole are meant to extend the knee in mid stance. However, the construction of this orthosis blocks any plantar flexion. Between initial contact and loading response, an excessive torque is applied to the lower leg and transmitted to the knee. This results in an enormous stress on the m. quadriceps (comparable to walking with a ski boot) [Goe, p. 134ff.; Per, p. 195].

### Effect of the Orthosis

- Initial contact and loading response: The defined pivot point and the adjustable range of motion enable a passive plantar flexion since they allow the eccentric work of the pretibial muscles. Therefore, the heel rocker is actively supported and no excessive torque is applied to the lower leg. The foot is lowered in a controlled manner against the force of the posterior spring unit.
- Mid stance: The anterior spring unit creates in combination with the long and rigid foot piece and the anterior shell a knee extension moment. This straightens the CP patient up and significantly improves the excessive knee flexion and lower leg incline (see p. 46f.). This is only possible if the knee flexion is not strong enough for the vector of the ground reaction force to run behind the anatomical pivot point. Furthermore, the patient gains stability in stance.

- Terminal stance: From mid stance to terminal stance, the anterior spring unit is preloaded up to the adjusted range of motion and stores the energy brought in by the body weight. The lever effect of the foot piece and the optimally adjusted dorsiflexion stop cause a heel lift at the right moment.
- Pre swing: From terminal stance to pre swing, the anterior spring unit releases the energy that assists the push off. Due to the construction of the orthosis and the supportive effect of the spring unit, the CP patient spends less energy when walking.



#### Why a toe spring?

When modifying the positive cast, a suitable toe spring should be taken into account. At rigid foot pieces, a toe spring is necessary to allow a heel-to-toe movement via the metatarsophalangeal joints (3. rocker) and to give more stability to the patient thanks to the forefoot contact in pre swing.

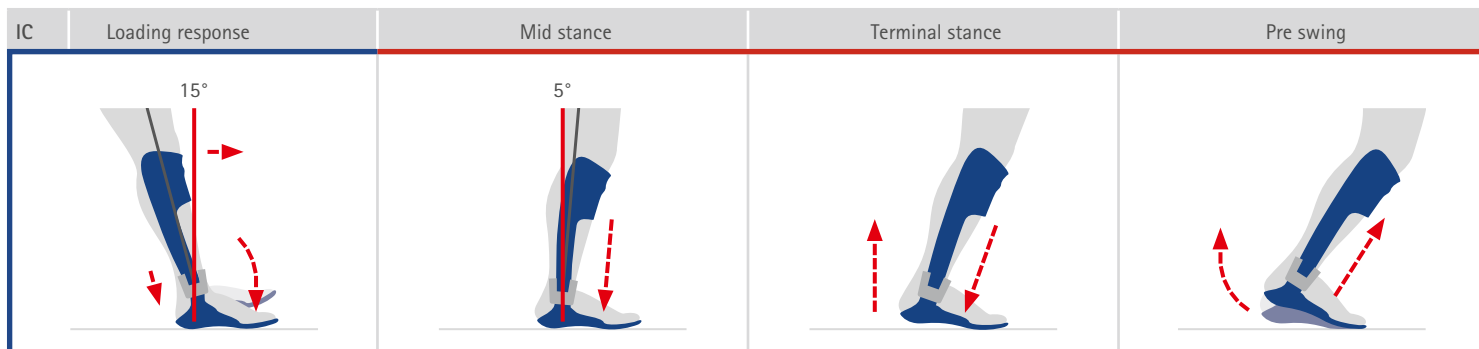

## Dissertation: Maximizing the efficacy of ankle foot orthoses in children with cerebral palsy

In her dissertation "Maximizing the efficacy of ankle foot orthoses in children with cerebral palsy", Yvette L. Kerkum treated 32 children with spastic cerebral palsy orthotically with the NEURO SWING system ankle joint within the scope of a large-scale Dutch study. The children's gaits were analysed and assessed based on a number of questions. The results of the study support the perspectives presented in this guide and are summarised here:

### Increasing of lower leg incline and joint angle in mid stance via increasing of pitch

The insertion of wedges under a rigid AFO (tuning) leads to a significant increase in the lower leg incline and the knee and hip flexion in mid stance [Ker, p. 49ff.].

### Changing of joint moments in mid stance via increasing of pitch

The insertion of wedges under a rigid AFO (tuning) leads to a significant increase in the knee flexion moment in mid stance [Ker, p. 49ff.].

### Changing of joint moments in mid stance via increasing of foot piece rigidity

Increasing the rigidity of the foot piece leads to a significant reduction in the knee flexion moment in mid stance [Ker, p. 49ff.].

### The mechanical properties of the NEURO SWING system ankle joint

As the spring units of the NEURO SWING system ankle joint are exchangeable, the AFO can be adapted to the patient's individual gait. Their design gives the spring units a threshold value below which there is no movement in the mechanical ankle joint (compression of spring units) when there are only small moments in the anatomical ankle joint. This threshold value supports knee extension at the beginning of the stance phase [Ker, p. 67ff.].

### The optimal spring force for CP patients with increased knee flexion in mid stance

The red and yellow spring units of the NEURO SWING system ankle joint are best suited for children with CP who present with increased knee flexion in mid stance (gait type 4 and 5). The yellow spring unit offers an optimal balance of spring force and range of motion and makes the best contribution to improving the push off with the resulting high energy return. The red spring unit normalises the joint angles the most efficiently with its relatively high rigidity and low range of motion [Ker, p. 67ff.].

### Reduced energy consumption when walking with the yellow spring unit

The improvement in energy consumption when walking with the yellow spring unit is due to the improvement of the joint angles and moments in the stance phase rather than the supporting of the push off [Ker, p. 79ff.].

### Reduced energy consumption when walking with an AFO and optimal spring force

Thanks to the optimal spring force, the patient can significantly reduce their energy consumption when walking with an AFO compared to walking with only shoes [Ker, p. 109ff.].

### Improved knee angle when walking with an AFO and optimal spring force

The optimal spring force makes it possible to reduce the CP patients' excessive knee flexion in mid stance significantly when walking with an AFO [Ker, p. 109ff.].

### Improved lower leg incline when walking with an AFO and optimal spring force

Thanks to the optimal spring force, the lower leg incline is significantly reduced when walking with an AFO compared to walking with only shoes [Ker, p. 109ff.].

### No time needed to get used to the new AFO

Even after a time of getting used to the AFO, no further improvement is noted in the important gait parameters (time-distance parameter, joint angles, joint moments). As such, no time for getting used to the appliance needs to be provided in routine clinical practice [Ker, p. 129ff.].



## Further Studies on NEURO SWING

In addition to the dissertation described above, the NEURO SWING system ankle joint has been employed in a wide range of studies since 2012, primarily for the indication of cerebral palsy. The results of these studies were presented as posters or presentations at various national and international conferences and/or published in renowned journals.

Block J, Heitzmann D, Alimusaj M et al. (2014): *Effects of an ankle foot orthosis with a dynamic hinge joint compared to a conventional orthosis – a case study*. OTWorld 2014. Leipzig, Germany, May 2014.

Gentz R, Friebus F (2012): Das Neuro Swing Systemknöchelgelenk. Seine Verwendung in der Orthesenversorgung für Patienten mit Cerebralparese. *Orthopädie Technik* 63(8): 35-41.

Kerkum YL, Harlaar J, Buizer AI et al. (2013): Optimising Ankle Foot Orthoses for children with Cerebral Palsy walking with excessive knee flexion to improve their mobility and participation; protocol of the AFO-CP study. *BMC Pediatrics* 13(1): 17.

Kerkum YL, Brehm MA, Buizer AI et al. (2014): Defining the mechanical properties of a spring-hinged ankle foot orthosis to assess its potential use in children with spastic cerebral palsy. *Journal of applied biomechanics* 30(6): 728-731.

Kerkum YL, Brehm MA, Hutten K et al. (2015): Acclimatization of the gait pattern to wearing an ankle-foot orthosis in children with spastic cerebral palsy. *Clinical biomechanics* 30(6): 617-622.

Kerkum YL, Buizer AI, Noort JC et al. (2015): The Effects of Varying Ankle Foot Orthosis Stiffness on Gait in Children with Spastic Cerebral Palsy Who Walk with Excessive Knee Flexion. *PLoS one* 10(11): e0142878.

Kerkum YL, Houdijk H, Brehm MA et al. (2015): The Shank-to-Vertical-Angle as a parameter to evaluate tuning of Ankle-Foot Orthoses. *Gait & Posture* 42(3): 269-274.

Kerkum YL, Harlaar J, Buizer AI et al. (2016): An individual approach for optimizing ankle-foot orthoses to improve mobility in children with spastic cerebral palsy walking with excessive knee flexion. *Gait & Posture* 46: 104-111.

Sabbagh D, D'Souza S, Schäfer C et al. (2022): Optimizing Spring Hinged Ankle Foot Orthoses for Patients with Neurological Gait Disorders Using Separate Adjustability of Plantarflexion and Dorsiflexion Resistance. *Gait & Posture* 97 (Suppl. 1): 152-153

Sabbagh D, Fior J, Gentz R (2016): Long-term effects of a dynamic ankle foot orthosis on a patient with cerebral palsy following ischemic perinatal stroke – A case study. *Gait & Posture* 49 (Suppl. 2): 224.

Sabbagh D, Fior J, Gentz R (2014): The observance of biomechanical effects on the estimation of common ankle foot orthoses in cerebral palsy. *Gait & Posture* 39 (Suppl. 1): 95-96.

Sabbagh D, Fior J, Gentz R (2013): A Critical Consideration on Common Orthotic Treatment Concepts for Gait Problems in Cerebral Palsy. *Journal of Children's Orthopaedics* 7(4): 331.

Skaaret I (2012): *Evaluation of Ankle Joint Stiffness on Gait Function in Neuromuscular Diagnoses: a Case Study*. 9. Nordiske Ortopeditekniske Kongress. Lillestrøm, Norway, November 2012.

Wolf S, Block J, Heitzmann D et al. (2013): Kinetics of an ankle foot orthosis with a dynamic hinge joint for children with neuromuscular disorders. *Journal of Children's Orthopaedics* 7(4): 331.

**AFO**

(ankle-foot orthosis): term for an orthosis encompassing the ankle joint and the foot

**Amsterdam Gait Classification**

Classification of ↑ pathological gait patterns of CP patients into five gait types. It evaluates the position of the knee and contact of the foot with the floor in mid stance. The Amsterdam Gait Classification was developed at the VU University Medical Center in Amsterdam assisted by Prof Dr Jules Becher.

**Botulinum Toxin**

Trade names include Botox®. Botulinum toxin is one of the most powerful neurotoxins known. The toxic proteins inhibit the signal transmission of the nerve cells to the muscle.

**Cerebral Connection**

(from Latin *cerebrum* = [in broadest sense] brain): The brain saves control programmes for complex movement patterns. Repetitions of ↑ physiological movement patterns lead to corrections of these control programmes in the brain. In turn, each environmental disturbance can result in a repeated control programme error and thus in a ↑ pathological movement pattern.

**Cerebral Palsy**

(abbr. CP): Disorder of the muscle tone and muscle coordination caused by damage to the central nervous system before, during or after birth. Depending on the type of damage, paralyzes can occur as ↑ hemiplegia, ↑ diplegia or ↑ paraplegia. For many patients, these paralyzes may be accompanied by ↑ spasticity.

**Concentric**

(from Latin *con* = with; *centrum* = centre): moving towards a centre; having a common centre. In a mechanical context this means that the force is applied exactly in the centre. In a ↑ physiological context, a muscle performs concentric work by shortening itself and thus causing a joint movement.

**Contracture**

(from Latin *contrahere* = to tighten): tissue shortening or shrinking, e.g. of certain muscles or tendons. This leads to a reversible or irreversible mobility restriction or fixed deformity of the adjoining joints. There are elastic and rigid contractures.

**Crouch Gait**

gait pattern with permanently flexed hips and knees

**DAFO**

(dynamic ankle-foot orthosis): dynamic lower leg orthosis.

The term DAFO is internationally used for ↑ SMOs as well as for partially flexible ↑ polypropylene ↑ AFOs. The present use of this term is ambiguous since AFOs with joint should also be named ↑ dynamic AFOs.

**Diplegia**

(from Greek *dis* = twice, double; *plege* = stroke, paralysis): bilateral paralysis. In diplegia, two parts of the body (e.g. both arms or both legs) are affected.

**Disc Spring**

A conical shell which can be loaded along its axis either statically or dynamically. Can be used as a single spring or a stack of springs. In a column, a spring stack can consist of either single disc springs or parallel spring sets. The geometric form of the disc spring leads to a ↑ concentric force absorption and hence to an almost linear spring characteristic curve.

**Dorsal**

(from Latin *dorsum* = back): belonging to the back, located at the back. Positioning on the foot: on the dorsal foot side.

**Dorsiflexion**

Lifting of the foot or reduction of the angle between lower leg and foot. It is called dorsiflexion because of this movement (↑ flexion). Functionally, however, it is a stretching movement in the sense of an ↑ extension. The countermovement of ↑ plantar flexion.

**Dorsiflexion Stop**

Constructional element of an orthosis which limits the degree of ↑ dorsiflexion. The dorsiflexion stop activates the forefoot lever, thereby creating an area of support. Furthermore, a dorsiflexion stop causes together with the orthosis' foot piece a knee extension moment and, starting at terminal stance, a heel lift.

**Dynamic**

(from Greek *dynamikos* = active, strong): displaying movement, characterised by momentum and energy. Thus, a dynamic ↑ AFO enables a defined movement in the anatomical ankle joint.

**Eccentric**

(from Latin *ex* = outside; *centro* = centre): located outside of a centre or away from a centre. In a mechanical context this means that the force is applied off-centre. In a ↑physiological context, a muscle performs eccentric work by actively extending itself and controlling a joint movement by decelerating it.

**Extension**

(from Latin *extendere* = to extend): active or passive straightening of a joint. Extension is the countermovement of bending (↑flexion) and characteristically increases the joint angle.

**Flexion**

(from Latin *flectere* = to bend): active or passive bending of a joint. Bending is the countermovement of straightening (↑extension) and characteristically reduces the joint angle.

**FRAFO**

(floor-reaction AFO): solid orthosis with anterior shell which provides a knee or hip extension moment starting at terminal stance. FRAFOs can be made of ↑polypropylene as well as of carbon. They either have a rigid or a partially flexible foot piece. However, the name FRAFO is misleading since other ↑AFOs also interact with the ↑ground reaction force.

**Ground Reaction Force**

(abbr. GRF): force generated in the ground as a counterreaction to the body weight. The ground reaction force vector is a theoretical line representing the size, origin and direction of action of the ground reaction force.

**Heel Lever**

A lever, which uses the ↑point of heel strike as the pivot point and the distance of the point of heel strike to the anatomical ankle joint as the lever arm. At initial contact, the ↑ground reaction force running ↑dorsally from the ankle causes a rotation around the point of heel strike.

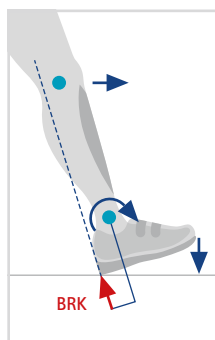
**Heel Rocker**

Involves the complete rotation of the foot around the ↑point of heel strike. It occurs in the anatomical ankle joint between initial contact and loading response: from terminal swing to initial contact, the swing leg "drops" to the ground from a height of about 1cm. The ↑ground reaction force becomes effective at the point of heel strike. Its force vector (broken line) runs dorsally from the ankle. The resulting ↑heel lever creates a plantar flexion moment in the ankle, which lowers the foot. The ↑m. tibialis anterior works ↑eccentrically against this movement, thus allowing a controlled foot drop.

**Hemiplegia**

(from Greek *hemi* = half; *plege* = stroke, paralysis): unilateral paralysis. A hemiplegia is the complete paralysis on one side of the body.

**Hinged AFO**

The classic hinged ↑AFO is an orthosis with posterior shell made of ↑polypropylene with an elastomer spring joint or a simple coil spring joint. Hinged AFOs allow a ↑dorsiflexion in the anatomical ankle joint. In most cases, the used elastomer spring joints are not strong enough to allow a ↑plantar flexion and, at the same time, keep the foot in ↑neutral position during swing phase. That is why the plantar flexion in hinged AFOs is blocked in these cases.

**Insufficiency**

insufficient function or inadequate performance of an organ or organ system (e.g. the muscular system)

**Interdisciplinary**

(from Latin *inter* = between): concerning the cooperation between several fields; cross-disciplinary

**Ischiocrural Muscles (1)**

Hamstrings. Located on the ↑dorsal side (back) of the thigh. In the hip joint, the ischiocrural muscles cause an ↑extension, whereas in the knee joint they cause a ↑flexion.

**M. Gastrocnemius (2)**

*Musculus gastrocnemius*: calf muscle. Two-headed muscle that causes the ↑plantar flexion of the foot. Part of the ↑m. triceps surae.

**M. Psoas Major (3)**

*Musculus psoas major*: "greater lumbar muscle". Internal hip muscle that starts in lumbar vertebra and flexes the thigh at the hip joint and rotates it outwards.

**M. Quadriceps (4)**

*Musculus quadriceps femoris*: four-headed muscle of the femur. The largest muscle in the body. It causes the extension of the lower leg in the knee joint. It consists of the following submuscles: musculus rectus femoris, musculus vastus medialis, musculus vastus lateralis and musculus vastus intermedius.

**M. Soleus (5)**

*Musculus soleus*: lower leg muscle. Its tendon and the one of the ↑m. gastrocnemius together form the Achilles tendon. It is involved in the ↑plantar flexion of the foot. Part of the ↑m. triceps surae.

**M. Tibialis Anterior (6)**

*Musculus tibialis anterior*: anterior tibial muscle. A muscle running from the tibia to the medial edge of the foot, which causes the ↑dorsiflexion of the foot.

**M. Triceps Surae (2 and 5)**

*Musculus triceps surae*: three-headed calf muscle. Summarising term for the two-headed ↑m. gastrocnemius and the ↑m. soleus.

**M. Vastus Lateralis (4a)**

*Musculus vastus lateralis*: lateral aspect of femur, from back of the thigh to the patella pulling part of the ↑m. quadriceps. It is involved in the ↑extension of the lower leg in the knee joint.

**Muscle Atrophy**

(from Greek *atrophia* = depletion, emaciation): visible decrease in the circumference of a skeletal muscle due to reduced strain

**Neutral Position**

Refers to the body position that a person assumes in a normal, upright, approximately hip-width stance. The joint's range of motion is determined in neutral position.

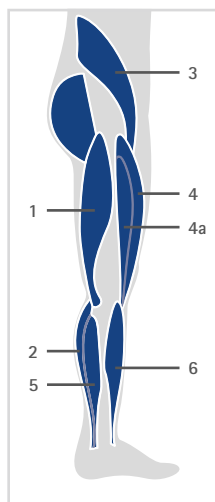
**Paraplegia**

(from Greek *para* = beside, near; *plege* = stroke, paralysis): complete paralysis of two symmetrical extremities (most often legs)

**Pathological**

(from Greek *pathos* = pain; disease): abnormally (changed)

**Physiological**

(from Greek *physis* = nature; *logos* = doctrine): concerning the natural life processes

**Plantar**

(from Latin *planta* = sole of the foot): concerning the sole of the foot, towards the sole of the foot

**Plantar Flexion**

Lowering of the foot or increase in the angle between lower leg and foot. Countermovement of ↑dorsiflexion.

**Plantar Flexors**

muscles causing the lowering of the foot, see ↑plantar flexion

**Point of Heel Strike**

point where the heel first touches the ground at initial contact

**Polypropylene**

(abbr. PP): group of thermoformable and weldable plastics. Often used for the production of simple orthoses. Economical manufacturing technique. The considerably higher weight is a disadvantage compared to materials of higher quality, such as carbon fibre, that offer the same rigidity.

**Posterior-Leaf-Spring AFO**

(from Latin *posterior* = back): lower leg orthosis with leaf spring attached behind the Achilles tendon, mostly made of carbon fibre

**Pretibial**

(from Latin *prae* = before; *tibia* = shinbone): situated in front of the tibia

**Push Off**

Toe-off during pre swing. This accelerates the leg into a forward movement.

### Rockers

Rotations around three different points of the foot in stance phase: 1. rocker (heel rocker) = rotation of the foot around the heel and of the lower leg around the anatomical ankle joint during initial contact and loading response, 2. rocker (ankle rocker) = rotation of the lower leg around the ankle in mid stance, 3. rocker (toe rocker) = rotation of the hindfoot around the heads of the metatarsal bones in terminal stance, 4. rocker = combined rotation around the ankle and the heads of the metatarsal bones in pre swing.

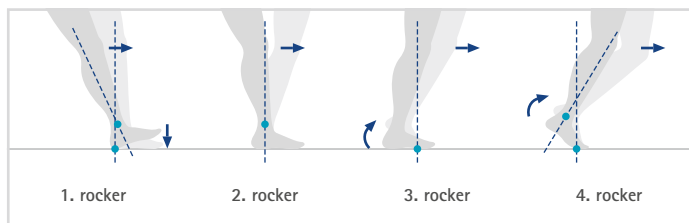

### SAFO

(solid ankle-foot orthosis): rigid lower leg orthosis. The term SAFO is used internationally for rigid  $\uparrow$ AFOs made of  $\uparrow$ polypropylene. The present use of this term is ambiguous since static AFOs are also rigid.

### Sensorimotor

Interaction of sensory and motor parts of the nervous system. For example, the sensory impressions from the soles of the feet influence the function of certain muscles.

### SMO

(supramalleolar orthosis): supramalleolar orthosis made of reinforced leather or  $\uparrow$ polypropylene. If the Achilles tendon area is not covered, movement in the anatomical ankle joint is possible. That is why SMOs can possess  $\uparrow$ dynamic properties. If the Achilles tendon is covered, the  $\uparrow$ plantar flexion is limited.

### Spasmolytic

(from Greek *spasmos* = cramp): relaxant drug. It decreases the tone of the smooth muscles or reduces muscle tension.

### Spasticity

(from Greek *spasmos* = cramp): an intermittent or sustained involuntary muscle activation caused by a damaged first motor neuron, which is responsible for sensorimotor functions [Pan, p. 2ff.].

### Static

(from Greek *statikos* = standing, causing to stand): the equilibrium of forces, concerning statics, in equilibrium, at rest, standing still. A static  $\uparrow$ AFO does not allow any movement in the anatomical ankle joint.

### Tibial Progression

(from Latin *procedere* = proceed, increase): movement of the tibia (shin-bone) in direction of movement around the anatomical ankle joint in mid stance. Also known as ankle rocker ( $\uparrow$ rockers).

- | Abbr.  | Source   | Page                       | Abbr.  | Source   | Page                      |
|--------|--|----------------------------|--------|--|---------------------------|
| [Aud]  | Audo O, Daly C (2017): Standing activity intervention and motor function in a young child with cerebral palsy. <i>Physiotherapy Theory and Practice</i> 33(2): 162-172. _____                        | 6                          | [Mol]  | Molenaers G, Desloovere K (2009): Pharmacologic Treatment with Botulinum Toxin. In: [Gag], p. 363-380. _____   | 5                         |
| [Bec]  | Becher JG (2002): Pediatric Rehabilitation in Children with Cerebral Palsy: General Management, Classification of Motor Disorders. <i>Journal of Prosthetics and Orthotics</i> 14(4): 143-149. _____ | 26, 30, 34, 38, 42         | [Nov1] | Novacheck TF, Kroll GJ, Gent G et al. (2009): Orthoses. In: [Gag], p. 327-348. _____   | 7, 8, 21, 28              |
| [Bre]  | Brehm MA (2007): <i>The Clinical Assessment of Energy Expenditure in Pathological Gait</i> . Dissertation. Vrije Universiteit/medical center Amsterdam. _____  | 38, 42                     | [Nov2] | Novacheck TF (2008): Orthoses for cerebral palsy. In: Hsu JD, Michael JW, Fisk JR (eds.): <i>AAOS Atlas of Orthoses and Assistive Devices</i> , 4th edition. Philadelphia: Mosby/Elsevier, p. 487-500. _____                 | 17, 21                    |
| [Doe]  | Döderlein L (2007): <i>Infantile Zerebralparese. Diagnostik, konservative und operative Therapie</i> . Darmstadt: Steinkopff. _____  | 4                          | [Õun]  | Õunpuu S, Thomason P, Harvey A et al. (2009): Classification of Cerebral Palsy and Patterns of Gait Pathology. In: [Gag], p. 147-166. _____  | 24                        |
| [Gag]  | Gage JR et al. (2009): <i>The Identification and Treatment of Gait Problems in Cerebral Palsy</i> , 2nd edition. London: Mac Keith Press. _____  | 58, 59                     | [Owe]  | Owen E (2010): The Importance of Being Earnest about Shank and Thigh Kinematics especially when using Ankle-Foot Orthoses. <i>Prosthetics and Orthotics International</i> 34(3): 254-269. _____                              | 9, 17                     |
| [Gag1] | Gage JR (2009): Gait Pathology in Individuals with Cerebral Palsy. Introduction and Overview. In: [Gag], p. 65. _____  | 4                          | [Pan]  | Pandyam AD, Gregoric M et al. (2005): Spasticity: clinical perceptions, neurological realities and meaningful measurement. <i>Disability and Rehabilitation</i> 27(1-2): 2-6. _____  | 57                        |
| [Gag2] | Gage JR et al. (2009): Section 5. Operative Treatment. In: [Gag], p. 381-578. _____  | 5                          | [Pea]  | Peacock WJ (2009): The Pathophysiology of Spasticity. In: [Gag], p. 89-98. _____   | 4                         |
| [Goe]  | Götz-Neumann K (2006): <i>Gehen verstehen. Ganganalyse in der Physiotherapie</i> . Stuttgart: Georg Thieme. _____  | 17, 19, 25, 32, 36, 40, 44 | [Per]  | Perry J, Burnfield JM (2010): <i>Gait Analysis: Normal and Pathological Function</i> , 2nd edition. Thorofare: Slack Inc. _____  | 5, 19, 25, 32, 36, 40, 44 |
| [Gra]  | Graham HK, Harvey A, Rodda J et al. (2004): The Functional Mobility Scale (FMS). <i>Journal of Pediatric Orthopaedics</i> 24(5): 514-520. _____  | 24                         | [Pek]  | Pekanovic A, Strobl W, Hafkemeyer U et al. (2022): Dynamic Standing Exercise using the Innowalk Device in Patients with Genetic and Acquired Motor Impairments. <i>Journal of Rehabilitation Medicine</i> 54: jrm00284 _____ | 6                         |
| [Gru]  | Grunt S (2007): Geh-Orthesen bei Kindern mit Cerebralparese. <i>Paediatrica</i> 18(6): 30-34. _____  | 2, 25, 28, 32, 36          | [Rod]  | Rodda J, Graham HK (2001): Classification of gait pattern in spastic hemiplegia and spastic diplegia: a basis for a management algorithm. <i>European Journal of Neurology</i> 8(Suppl. 5): 98-108. _____                    | 25                        |
| [Hor]  | Horst R (2005): <i>Motorisches Strategietraining und PNF</i> . Stuttgart: Georg Thieme. _____  | 5, 9, 17, 19               | [Rom]  | Romkes J, Hell AK, Brunner R (2006): Changes in muscle activity in children with hemiplegic cerebral palsy while walking with and without ankle-foot orthoses. <i>Gait &amp; Posture</i> 24(4): 467-474. _____               | 7                         |
| [Ker]  | Kerkum YL (2015): <i>Maximizing the efficacy of ankle foot orthoses in children with cerebral palsy</i> . Dissertation. Vrije Universiteit medical center Amsterdam. _____                           | 46, 47                     | [Rus]  | Russel D et al. (2002): <i>Gross Motor Function Measure (GMFM-66 &amp; GMFM -88) User's Manual</i> . London: Mac Keith Press. _____  | 24                        |
| [Kra]  | Krämer J (1996): <i>Orthopädie</i> . 4th edition. Berlin: Springer. _____  | 5                          |        |  |                           |

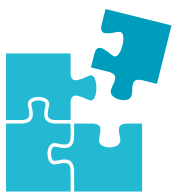

# Orthosis Configurator

PR0221-US-2023-09